

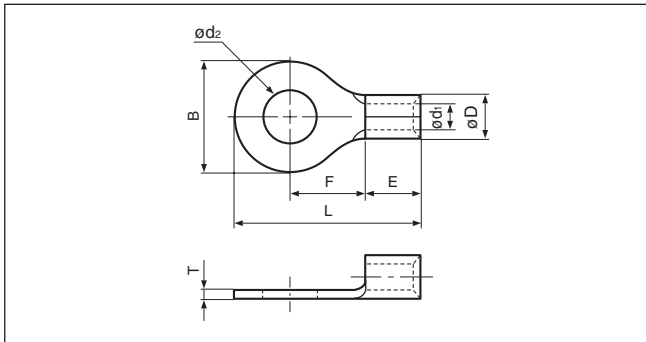

圆形端子 (R型) 非绝缘, 镀镍



适用电线 AWG#(mm ²)	螺栓孔尺寸		零件号	标准	尺寸mm (in.)								工具型号	数量/箱
	美制	米制			ϕd_2	B	L	F	E	ϕD	ϕd_1	T		
22~16 (0.25~1.65)	3-4	3	NIP1.25-3		3.2 (.126)	5.5 (.205)	11.5 (.453)	4.0 (.157)	4.8 (.189)	3.4 (.134)	1.7 (.067)	0.8 (.031)	YHT-2210 YA-4 BCT-0514L	1,000
	8	4	NIP1.25-M4		4.3 (.169)	6.6 (.260)	14.4 (.567)	6.3 (.248)						
	8	4	NIP1.25-4		4.3 (.169)	8.0 (.315)	15.8 (.622)	7.0 (.276)						
	10	5	NIP1.25-5		5.3 (.209)	8.0 (.315)	15.8 (.622)	7.0 (.276)						
	1/4	6	NIP1.25-6		6.4 (.252)	11.6 (.457)	21.7 (.854)	11.1 (.437)						
16~14 (1.04~2.63)	5/16	8	NIP1.25-8		8.4 (.331)	11.6 (.457)	21.7 (.854)	11.1 (.437)	4.8 (.189)	4.0 (.157)	2.3 (.091)	0.8 (.031)	YHT-2210 YA-4 BCT-0514L	1,000
	3-4	3	NIP2-S3.3		3.2 (.126)	6.4 (.252)	12.3 (.484)	4.3 (.169)						
	3-4	3	NIP2-3		3.2 (.126)	8.5 (.335)	16.8 (.661)	7.8 (.307)						
	5-6	3.5	NIP2-S3		3.7 (.146)	6.4 (.252)	12.3 (.484)	4.3 (.169)						
	5-6	3.5	NIP2-M3		3.7 (.146)	6.6 (.260)	14.4 (.567)	6.3 (.248)						
	8	4	NIP2-M4		4.3 (.169)	6.6 (.260)	14.4 (.567)	6.3 (.248)						
	8	4	NIP2-4		4.3 (.169)	8.5 (.335)	16.8 (.661)	7.8 (.307)						
	10	5	NIP2-5		5.3 (.209)	9.5 (.374)	16.8 (.661)	7.3 (.287)						
12~10 (2.63~6.64)	1/4	6	NIP2-6		6.4 (.252)	12.0 (.472)	21.8 (.858)	11.0 (.433)	6.8 (.268)	5.5 (.217)	3.4 (.134)	1.0 (.039)	YHT-2210 YA-4 BCT-0514L	500
	5/16	8	NIP2-8		8.4 (.331)	12.0 (.472)	21.8 (.858)	11.0 (.433)						
	8	4	NIP5.5-S4		4.3 (.169)	7.2 (.284)	15.7 (.618)	5.9 (.232)						
	8	4	NIP5.5-4		4.3 (.169)	9.5 (.374)	19.8 (.780)	8.3 (.327)						
	10	5	NIP5.5-5		5.3 (.209)	9.5 (.374)	19.8 (.780)	8.3 (.327)						
	1/4	6	NIP5.5-6		6.4 (.252)	12.0 (.472)	25.8(1.016)	13.0 (.512)						
8 (6.64~10.52)	1/4	6	NIP5.5-S6		6.4 (.252)	13.2 (.520)	22.4 (.882)	9.0 (.354)	8.5 (.335)	7.1 (.280)	4.5 (.177)	1.2 (.047)	YA-4 YA-5 YPT-60N YPT-150-1 BCT-0514L BCT-860L BCT-8150 YF-1 YET-60-1 E-4 YET-150-1	500
	5/16	8	NIP5.5-8		8.4 (.331)	15.0 (.591)	28.0(1.102)	13.7 (.539)						
	3/8	10	NIP5.5-10		10.5 (.413)	15.0 (.591)	28.0(1.102)	13.7 (.539)						
	8	4	NIP8-4		4.3 (.169)	12.0 (.472)	23.8 (.937)	9.3 (.366)						
	10	5	NIP8-5		5.3 (.209)	12.0 (.472)	23.8 (.937)	9.3 (.366)						
6 (10.52~16.78)	1/4	6	NIP8-6		6.4 (.252)	12.0 (.472)	23.8 (.937)	9.3 (.366)	10.5 (.413)	9.0 (.354)	5.8 (.228)	1.5 (.059)	YA-5 YPT-60N YPT-150-1 BCT-860L BCT-8150 YF-1 YET-60-1 E-4 YET-150-1	200
	5/16	8	NIP8-8		8.4 (.331)	15.0 (.591)	29.8(1.173)	13.8 (.543)						
	3/8	10	NIP8-10		10.5 (.413)	15.0 (.591)	29.8(1.173)	13.8 (.543)						
	1/2	12	NIP8-12		13.0 (.512)	20.0 (.787)	33.5(1.319)	15.0 (.591)						
	10	5	NIP14-5		5.3 (.209)	12.0 (.472)	29.8(1.173)	13.3 (.524)						
	1/4	6	NIP14-6		6.4 (.252)	12.0 (.472)	29.8(1.173)	13.3 (.524)						
6 (10.52~16.78)	5/16	8	NIP14-8		8.4 (.331)	16.0 (.630)	32.8(1.291)	14.5 (.571)	10.5 (.413)	9.0 (.354)	5.8 (.228)	1.5 (.059)	YA-5 YPT-60N YPT-150-1 BCT-860L BCT-8150 YF-1 YET-60-1 E-4 YET-150-1	100
	3/8	10	NIP14-10		10.5 (.413)	16.0 (.630)	32.8(1.291)	14.5 (.571)						
	1/2	12	NIP14-12		13.0 (.512)	22.0 (.866)	41.0(1.614)	19.5 (.768)						

注: 1) 有关最小订购批量的信息, 请垂询本公司。
2) 生产交货周期因产品类型而异。详情请垂询本公司。